

LUDLUM MODEL 44-9-18

AND

LUDLUM MODEL 44-9-19

ALPHA, BETA, & GAMMA DETECTORS

**July 2025
Serial Number PR254331 and Succeeding
Serial Numbers**

LUDLUM MODEL 44-9-18
AND
LUDLUM MODEL 44-9-19
ALPHA, BETA, & GAMMA DETECTORS

July 2025
Serial Number PR254331 and Succeeding
Serial Numbers



LUDLUM MEASUREMENTS, INC
501 OAK STREET, P.O. BOX 810
SWEETWATER, TEXAS 79556
325-235-5494, FAX: 325-235-4672

STATEMENT OF WARRANTY

Ludlum Measurements, Inc. warrants the products covered in this manual to be free of defects due to workmanship, material, and design for a period of twelve months from the date of delivery. The calibration of a product is warranted to be within its specified accuracy limits at the time of shipment. In the event of instrument failure, notify Ludlum Measurements to determine if repair, recalibration, or replacement is required.

This warranty excludes the replacement of photomultiplier tubes, G-M and proportional tubes, and scintillation crystals which are broken due to excessive physical abuse or used for purposes other than intended.

There are no warranties, express or implied, including without limitation any implied warranty of merchantability or fitness, which extend beyond the description of the face there of. If the product does not perform as warranted herein, purchaser's sole remedy shall be repair or replacement, at the option of Ludlum Measurements. In no event will Ludlum Measurements be liable for damages, lost revenue, lost wages, or any other incidental or consequential damages, arising from the purchase, use, or inability to use product.

RETURN OF GOODS TO MANUFACTURER

If equipment needs to be returned to Ludlum Measurements, Inc. for repair or calibration, please send to the address below. All shipments should include documentation containing return shipping address, customer name, telephone number, description of service requested, and all other necessary information. Your cooperation will expedite the return of your equipment.

**LUDLUM MEASUREMENTS, INC.
ATTN: SERVICE DEPARTMENT
501 OAK STREET
SWEETWATER, TX 79556**

**800-622-0828 325-235-5494
FAX 325-235-4672**

Table of Contents

<i>Introduction</i>	<i>1</i>
<i>Unpacking and Repacking</i>	<i>2</i>
<i>Specifications</i>	<i>2</i>
<i>Operating Procedures</i>	<i>3</i>
<i>Tube Replacement</i>	<i>4</i>
<i>Cleaning Instructions and Precautions</i>	<i>4</i>
<i>Parts List</i>	<i>5</i>
<i>Drawings and Diagrams</i>	<i>6</i>

Introduction

The Ludlum Model 44-9-18 and the Ludlum Model 44-9-19 are alpha, beta, and gamma detectors that are variations of the Ludlum Model 44-9, a fixed-handle Geiger Mueller “pancake” detector.

The size and shape of the Ludlum Model 44-9-19 provides easy handling for surveying or personnel monitoring. The Model 44-9-19 contains a halogen-quenched tube that is attached to a flexible arm. The flexible arm allows the detector head and tube to reach different angles to accommodate different surveys or frisking. The flexible arm is attached to an anodized aluminum handle that allows the length of the detector to be adjusted from 73.7 to 112 cm (29 to 44 in). (See picture below.)



Model 44-9-19

The Ludlum 44-9-18 is a GM detector with an extension handle. This detector is very similar to the Ludlum Model 44-9-19. The telescoping handle is attached to an aluminum housing that encloses the GM tube. The aluminum housing is attached to a flexible arm that enables the detector head and tube to reach different angles. The length of the Model 44-9-18 is 58.4 cm (23 in.), and with the handle fully extended, the detector is 91.4 (36 in.). See picture below.



Model 44-9-18

A 79% open stainless steel screen protects the thin mica window. The GM tube is easily replaceable if necessary. The detectors are energy dependent, over-responding by a factor of six in the 60 keV to 100 keV range when normalized to ¹³⁷Cs.

These detectors operate between 850-1000 volts, with a recommendation from the tube manufacturer of approximately 900 Vdc. Recommended instrument input sensitivity is approximately 30 mV or higher to prevent the detector from double pulsing (where the detector “counts” a single pulse from the instrument multiple times).

Caution!

The GM tube face can rupture above 8000 feet in altitude. When transporting this detector by air, use an airtight container to avoid sudden atmospheric changes that can result in tube failure.

The Model 44-9-18 and Model 44-9-19 will operate with any Ludlum instrument or equivalent that provides 900 Vdc and an input sensitivity of approximately 30 mV or higher.

Unpacking and Repacking

Remove the calibration certificate or detector functional check certificate and place it in a secure location. Remove the detector(s) and accessories (if applicable) and ensure that all items listed on the packing list are in the carton. If multiple detectors are included, refer to the calibration certificates for serial number (SN) matches. The serial number is located on the detector's bottom plate.

To return an instrument or detector for repair or calibration, provide sufficient packing material to prevent damage during shipment (see "Caution!" in Introduction section) and affix appropriate warning labels to promote careful handling.

Every returned instrument must be accompanied by an **Instrument Return Form**, which can be downloaded from the Ludlum website at www.ludlums.com. Find the form by clicking the "Support" tab and selecting "Service Center" from the drop-down menu. Then choose the appropriate Service Center division where you will find a link to the form.

Specifications

The specifications for the Model 44-9-18 and the Model 44-9-19 are the same except for the size and weight. The differences are at the end of this section.

Detector: pancake-type halogen quenched GM

Window: 2.0 ± 0.3 mg/cm² mica

Window Area: Active is 15.5 cm² (2.4 in²); Open is 12.3 cm² (1.9 in²)

Window Protective Screen: 79% open

Efficiency (4 π geometry): typically 5% for ¹⁴C; 22% for ⁹⁰Sr/⁹⁰Y; 15% for ⁹⁹Tc; 32% for ³²P; 15% for ²³⁹Pu; $\leq 1\%$ for ^{99m}Tc; and 0.2% for ¹²⁵I

Sensitivity: typically 3300 cpm per mR/hr (¹³⁷Cs gamma)

Energy Response: energy dependent (see graph on page 11)

H*(10) Energy Response (with optional filter 2002-1050): within 20% from 20 keV to 1.2 MeV

Dead Time: typically 80 microseconds

Compatible Instruments: general purpose survey meters, ratemeters, and scalers

Connector: series "C" (others available)

Construction: aluminum housing with beige powder-coat finish; stainless steel protective screen (79% open)

Temperature Range: -15 to 50 °C (5 to 122 °F); may be certified for -40 to 65 °C (-40 to 150 °F)

Ludlum Model 44-9-18

Size: 4.6 x 6.9 x 58.4 cm (1.8 x 2.7 x 23 in.) (H x W x L); 91.4 cm (36 in.) fully extended

Weight: 0.7 kg (1.5 lb)

Ludlum Model 44-9-19

Size 4.6 x 6.9 x 73.6 cm (1.8 x 2.7 x 29 in.) (H x W x L); maximum telescoping length 111.7 cm (44 in.)

Weight: 0.8 kg (1.75 lb)

Operating Procedures

CONNECTING TO AN INSTRUMENT

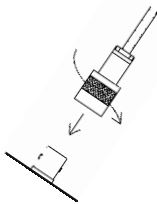

Connect one end of the cable provided to the detector by firmly pushing the connector together while twisting clockwise $\frac{1}{4}$ turn until latched. Repeat the process in the same manner with the other end of the cable and the instrument.

TESTING THE DETECTOR

1. Ensure that the instrument high voltage (HV) is at the proper setting for the detector (900 volts).
2. Connect the detector to the instrument and check for a proper background reading (typically 25-50 cpm at 8-15 $\mu\text{R/hr}$).
3. Expose the detector to a check source and verify that the instrument indicates within 20% of the check source reading from the last calibration. Alternatively, expose the detector to a source of known value and verify that the detector detects greater than or equal to the efficiency listed in the specification section of this manual.
4. Instruments and detectors which meet these criteria are ready for use. Failure to meet these criteria may indicate a malfunction in the detector.

Tube Replacement

1. Remove the back plate by removing the three screws.
2. Loosen the three set screws on the side of the tube housing.
3. Remove the old tube from the detector housing.
4. Remove the anode clip from the old tube.
5. Push the clip onto the anode housing.

Note:

Do not over-flex the wire when installing the clip, as damage may occur.

Caution!

The mica window of this tube is extremely thin and fragile. There is also a thin layer of material to prevent UV interference. This material may come off if touched, causing the detector to malfunction. **DO NOT TOUCH!**

6. Carefully install the tube with the window facing down in the housing.
7. Ensure the tube is flush against the screen and tighten the set screws.
8. Replace the back plate and retaining screws.
9. Recalibrate the instrument and detector before use.

Cleaning Instructions and Precautions

The detector may be cleaned externally with a damp cloth, using only water as the wetting agent. Do not immerse the instrument in any liquid. Observe the following precautions when cleaning:

1. Turn the instrument electronics OFF.
2. Allow the instrument to sit for one minute.
3. Disconnect the detector cable before cleaning the detector.

Parts List

Model 44-9-18 Alpha-Beta-Gamma Detector

Reference	Description	Part Number
UNIT	Completely Assembled Model 44-9-18 Alpha-Beta-Gamma Detector	47-2940
*	DETECTOR BODY	2002-950
*	HANDLE GRIP	7002-426
*	GM TUBE (LND 7311, TGM N1002)	01-5008
3 EA	SOCKET SET SCREWS (10-34 × ¼)	17-8560
*	PENCIL CLIP	01-5237
*	RESISTOR 3.3M	10-7044
*	CONNECTOR, UG706/U	4478-011
*	HV RED SILICONE WIRE	21-8550
*	PROTECTIVE SCREEN	21-9586
*	RED PROTECTIVE CAP	03-5476
*	FLEXIBLE ARM	2311187
*	INSIDE CON TUBE	2002-964
*	NUT	7002-565
*	ELASTIC SHELL	7002-548
*	STOP WASHER	7002-595
*	OUTSIDE TUBE	7002-966
4EA	SCREW-2-56 X 1/8 BH	17-8727

Model 44-9-19 Alpha-Beta-Gamma Detector

Reference	Description	Part Number
	Completely Assembled Model 44-9-19 Alpha-Beta-Gamma Detector	47-3224
*	HANDLE GR ASSEM	2002-951

Drawings and Diagrams

M 44-9-18 Telescoping Probe Drawing 2 X 963 (page 7)

M 44-9-18 Assembly Drawing 2 X 963A (page 8)

M 44-9-19 Pancake GM Tube Drawing 2 X 949 (page 9)

M 44-9-19 Assembly Drawing 2 X 949A (page 10)

Energy Response (page 11)

Beta Efficiencies (page 12)

Note:

The energy response and beta efficiencies for the Ludlum Model 44-9-18 and the Model 44-9-19 are the same as the responses and efficiencies for a Ludlum Model 44-9.

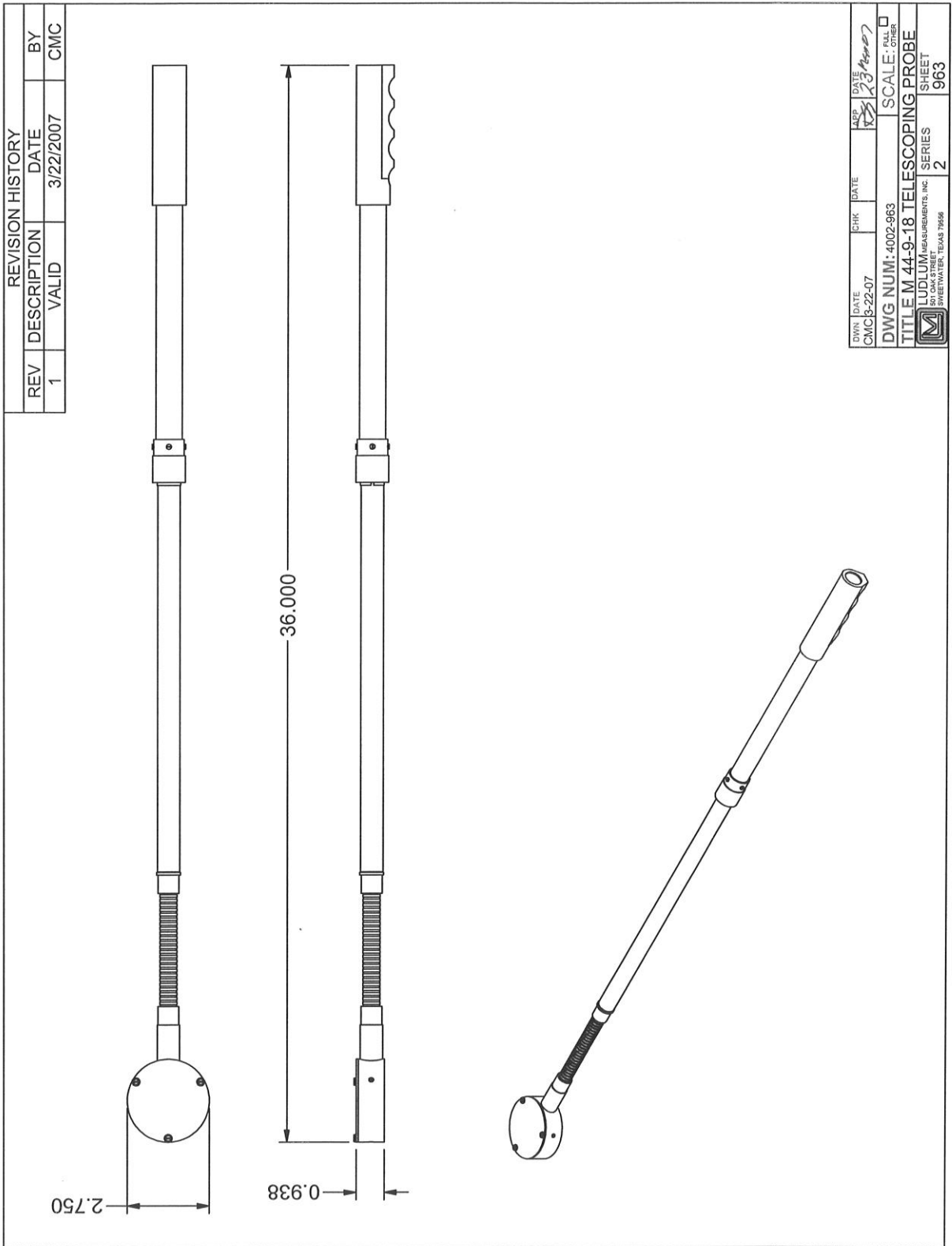

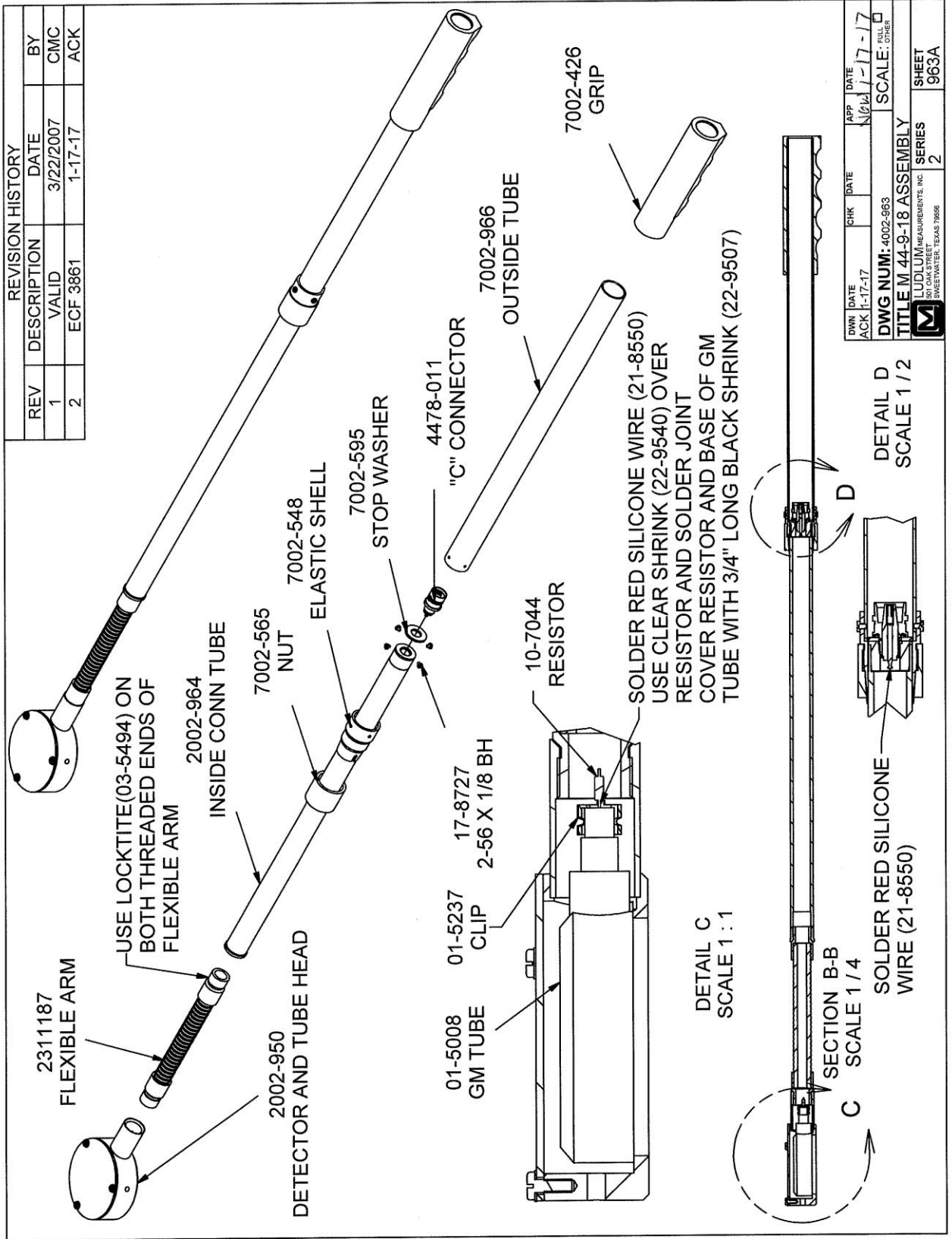

REVISION HISTORY			
REV	DESCRIPTION	DATE	BY
1	VALID	3/22/2007	CMC
2	ECF 3861	1-17-17	ACK

DWN DATE	CHK DATE	APP DATE
ACK 1-17-17		1-17-17
DWG NUM: 4002-963		
SCALE: 1:1		
TITLE M 44-9-18 ASSEMBLY		
LUDLUM MEASUREMENTS, INC.		
800 OAK STREET		
EVANSTON, ILL 60201		
SHEET	SERIES	2
963A		

Model 44-9-18 and Model 44-9-19 Alpha, Beta & Gamma Detectors

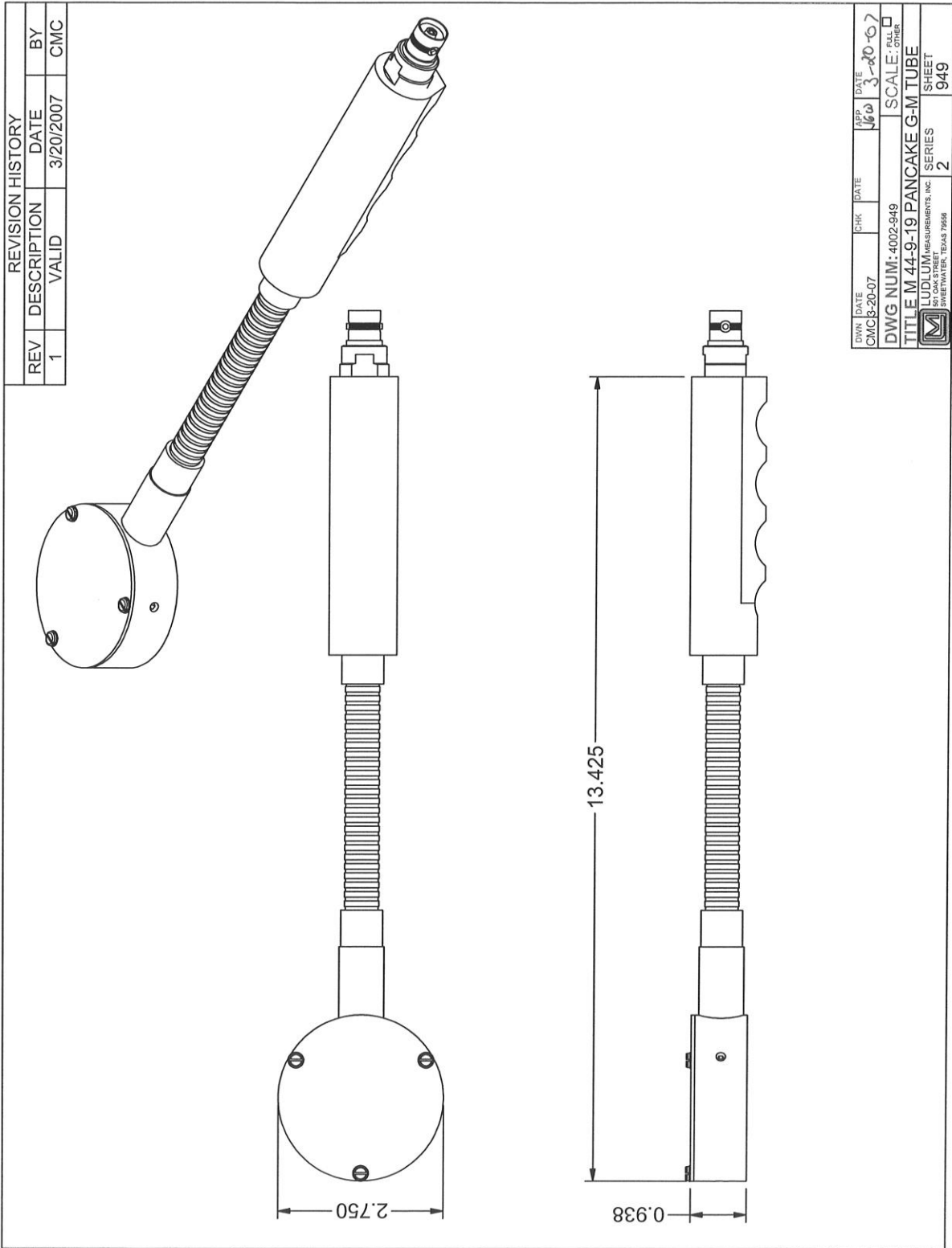

REVISION HISTORY			
REV	DESCRIPTION	DATE	BY
1	VALID	3/20/2007	CMC

OWN	DATE	CHK	DATE	APP	DATE
CMC	3-20-07				3-20-07
DWG NUM: 4002-949		SCALE: FULL			
TITLE M 44-9-19 PANCAKE G-M TUBE		OTHER			
LUDLUM MEASUREMENTS, INC.		SERIES		SHEET	
SWEETWATER, TEXAS 79556		2		949	

