

**LUDLUM MODEL 43-68,
43-68/1 AND 43-68/2
GAS PROPORTIONAL DETECTORS**

**February 2011
Serial Number 159017 and Succeeding
Serial Numbers**

**LUDLUM MODEL 43-68,
43-68/1 AND 43-68/2
GAS PROPORTIONAL DETECTORS**

**February 2011
Serial Number 159017 and Succeeding
Serial Numbers**



LUDLUM MEASUREMENTS, INC.
501 OAK STREET, P.O. BOX 810
SWEETWATER, TEXAS 79556
325-235-5494, FAX: 325-235-4672

STATEMENT OF WARRANTY

Ludlum Measurements, Inc. warrants the products covered in this manual to be free of defects due to workmanship, material, and design for a period of twelve months from the date of delivery. The calibration of a product is warranted to be within its specified accuracy limits at the time of shipment. In the event of instrument failure, notify Ludlum Measurements to determine if repair, recalibration, or replacement is required.

This warranty excludes the replacement of photomultiplier tubes, G-M and proportional tubes, and scintillation crystals which are broken due to excessive physical abuse or used for purposes other than intended.

There are no warranties, express or implied, including without limitation any implied warranty of merchantability or fitness, which extend beyond the description of the face there of. If the product does not perform as warranted herein, purchaser's sole remedy shall be repair or replacement, at the option of Ludlum Measurements. In no event will Ludlum Measurements be liable for damages, lost revenue, lost wages, or any other incidental or consequential damages, arising from the purchase, use, or inability to use product.

RETURN OF GOODS TO MANUFACTURER

If equipment needs to be returned to Ludlum Measurements, Inc. for repair or calibration, please send to the address below. All shipments should include documentation containing return shipping address, customer name, telephone number, description of service requested, and all other necessary information. Your cooperation will expedite the return of your equipment.

**LUDLUM MEASUREMENTS, INC.
ATTN: REPAIR DEPARTMENT
501 OAK STREET
SWEETWATER, TX 79556
800-622-0828 325-235-5494
FAX 325-235-4672**

Table of Contents

General	1
Specifications	2
Hook-Up	4
Flush	5
Detector Performance	6
Static Operation	6
Recharge	7
Parts List	8
Drawings and Diagrams	9

General

The Ludlum Model 43-68, Model 43-68/1 and Model 43-68/2 are gas proportional detectors, each having an open window area of 100 cm². They are designed for alpha and beta survey and are compatible with a number of counting instruments.

The three models are identical in performance specifications and vary from each other only in the location of the quick disconnect gas fittings. Both the Model 43-68 and Model 43-68/1 have the two fittings “topside.” The Model 43-68 fittings are on the same end as the cable connector, while the Model 43-68/1 has fittings on opposite corners. The Model 43-68/2 fittings are on the narrow side of the end of the detector opposite the handle. The cable connector is also located there on the Model 43-68/2. (Refer to individual assembly drawings for details.)

Instructions and procedures in this manual apply to all three models

NOTE: *When changing the Mylar window on a detector, it is not necessary to recalibrate the instrument as long as a functional check is performed on the instrument and its readings are consistent with the readings before the window was replaced.*

Specifications

Window Thickness: typically two layers of Mylar 0.8 mg/cm²), other thicknesses available

Window Area: typically 126 cm² active, 100 cm² open

Counting Gas: P-10 (10% methane, 90% argon) is recommended. Other counting gases are also acceptable.

Gas Recharge: expected time of operation on static charge with 0.99 m (39 in.) cable:

- Gross counting mode is 15 hours or longer.
- Alpha-beta mode is 5 hours or longer.

Background:

- Alpha is 3 counts per minute (cpm) or less when operating at alpha-only plateau region.
- Beta-gamma is typically 350 cpm or less (in a 10μR/hr field).

Efficiency (4π geometry):

- typical values for gross countin: 20%-²³⁹Pu; 15%-¹⁴C; 30%-⁹⁹Tc; 20%-⁹⁰Sr/⁹⁰Y
- typical values for alpha-beta counting: 17.5%-²³⁹Pu; 20%-⁹⁰Tc; 20%-⁹⁰Sr/⁹⁰Y

Operating Voltage:

- Alpha is typically 1100-1400 volts.
- Beta-gamma is typically 1600-1800 volts.

Counter Threshold Setting: typically 2-5 mV for scaler or gross counting instrument

Size: 7.4 x 11.7 x 19.8 cm (2.9 x 4.6 x 7.8 in.) (H x W x L)

Weight: 0.9 kg (2 lb)

Gas Connectors: double-end shut-off quick disconnects

Hook-Up

NOTE: Plastic dust caps should **always** be in place on detector gas connectors when gas lines are disconnected, except during a fast flush. Dust caps prevent dust and other materials from interfering with the function of the check valves and should be in place when the detector is operating on a static charge.

- Connect counting gas output and input lines to detector.

RECOMMENDED EQUIPMENT

- (1) **Dual-Stage Regulator:** allows for better low-pressure regulation
- (2) **Needle Valve** between second regulator stage and flowmeter for easier flow adjustment
- (3) **Flowmeters:** range of 0-150 cc/min (cubic centimeters/minute)
- (4) **Water Pressure Gauge:** (optional) range of 0-25 inches of water

Flush

CAUTION: The Model 43-68 uses double-end shut-off quick connects. Both the male and female quick connects have to be connected to allow counting gas to flow through the detector.

- Connect output gas line from detector to output flowmeter.
- Connect input and gas lines from main supply through the regulator and input flow meter.
- Turn main supply on and flush detector at 100-140 cc/min or 10.2 cm (4 in.) of water pressure at 1-2 psi gauge pressure for 15 minutes.

NOTE: A faster flush time can be realized if the output gas line (only) is removed at the output flowmeter and the flow rate maximized. Flush time may be reduced to 5 minutes. (Note that the quick disconnect fitting should not be removed. With the fitting in place, gas flows out the connection. With the fitting removed, a check valve is actuated that prevents output flow.)

CAUTION: The main supply should be reduced to less than 50 cc/min before the output gas line is reconnected.

- After flush is complete, set flow to 30-50 cc/min.
- Check output flowmeter. Determine detector leakage to be less than 5 cc/min.

Detector Performance

ALPHA PLATEAU: Determine the plateau region of the background and alpha source counting curves for the applied voltage range of 1100-1400 volts. Use 50-volt increments and set the counting instrument input sensitivity at 4 mV. The operating voltage should be approximately 1250 volts. The background count should be 3 cpm or less. The operating voltage will increase with a higher input sensitivity. Check each quadrant of the detector face for statistically uniform response; that is, ensure that each quadrant reading is within $\pm 10\%$ of the average of the readings. If the count is not statistically uniform, check for light leaks in the window and repeat flush procedures.

BETA-GAMMA PLATEAU: Determine the plateau region in the background and beta-gamma source counting curves for the applied voltage range of 1550 volts to 1900 volts or from 1550 volts to when either the source or background count rate increases dramatically. Use 50-volt increments and leave the input sensitivity at 4 mV. The operating voltage should be approximately 1700-1750 volts, with the background count at 350 cpm or less. Setting instrument input sensitivity greater than 4 mV will increase the operating voltage.

Static Operation

- Check detector for proper operation, for appropriate source count, and gas leakage.

- Disconnect output and input male quick connects.

- Turn main supply to OFF.
- Check source count before and after static operation. A decrease in detector efficiency should be less than 10% in 15 hours from when the detector is disconnected from the main gas supply for gross counting or 5 hours for alpha-beta counting.

Recharge

- Connect input and output quick connects.
- Turn main supply to ON at 30-50 cc/min for routine recharge, or refer to flush procedures for faster flush time.

Parts List

<u>Description</u>	<u>Part Number</u>
Completely Assembled Model 43-68 Gas Probe	47-2005
Completely Assembled Model 43-68/1 Gas Probe	47-2013
Completely Assembled Model 43-68/2 Gas Probe	47-2017
Body – Model 43-68	7342-152
Body – Model 43-68/1	7342-161
Body – Model 43-68/2	7339-138
Cover Plate	7342-156
Hex Screen	7342-157
Reversible Handle	7342-133
Electrode Plate	7342-146
Window Assembly	4342-097
Screw-in "C" Connector	13-7751
Quick Disconnect Fitting	13-7912
Stem (2 each)	
Quick Disconnect Fitting	13-7920
Pipe (2 each)	
Standoff (8 each)	18-8780
Brass Knurled Nut (2 each)	20-9074
Silicone Cord 1.07 m (3.5 ft)	22-9631

Drawings and Diagrams

Assembly View (Model 43-68), Drawing 342 x 97

Assembly View (Model 43-68), Drawing 339 x 70

Assembly View (Model 43-68/1), Drawing 339 x 105

Assembly View (Model 43-68/2), Drawing 339 x 104

Model 43-68, 43-68/1, 43-68/2 Gas Proportional Detector

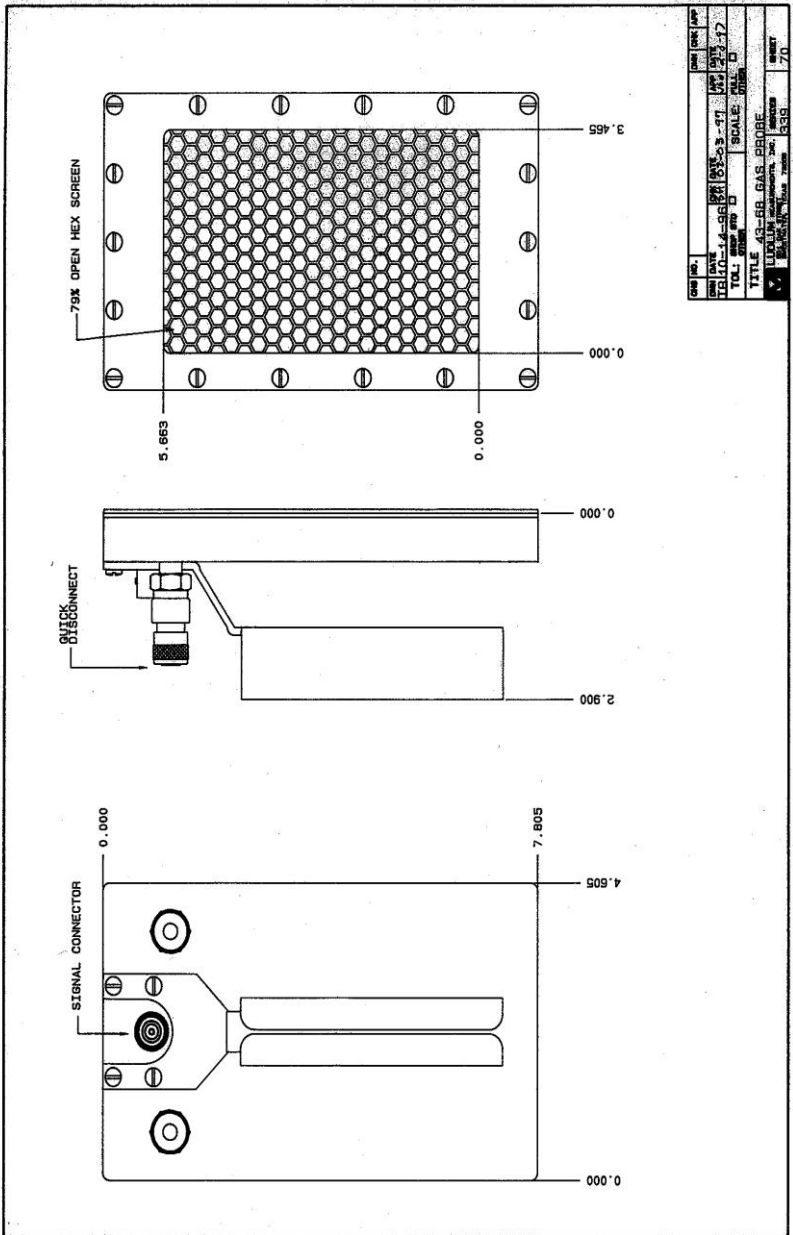

Model 43-68, 43-68/1, 43-68/2 Gas Proportional Detector

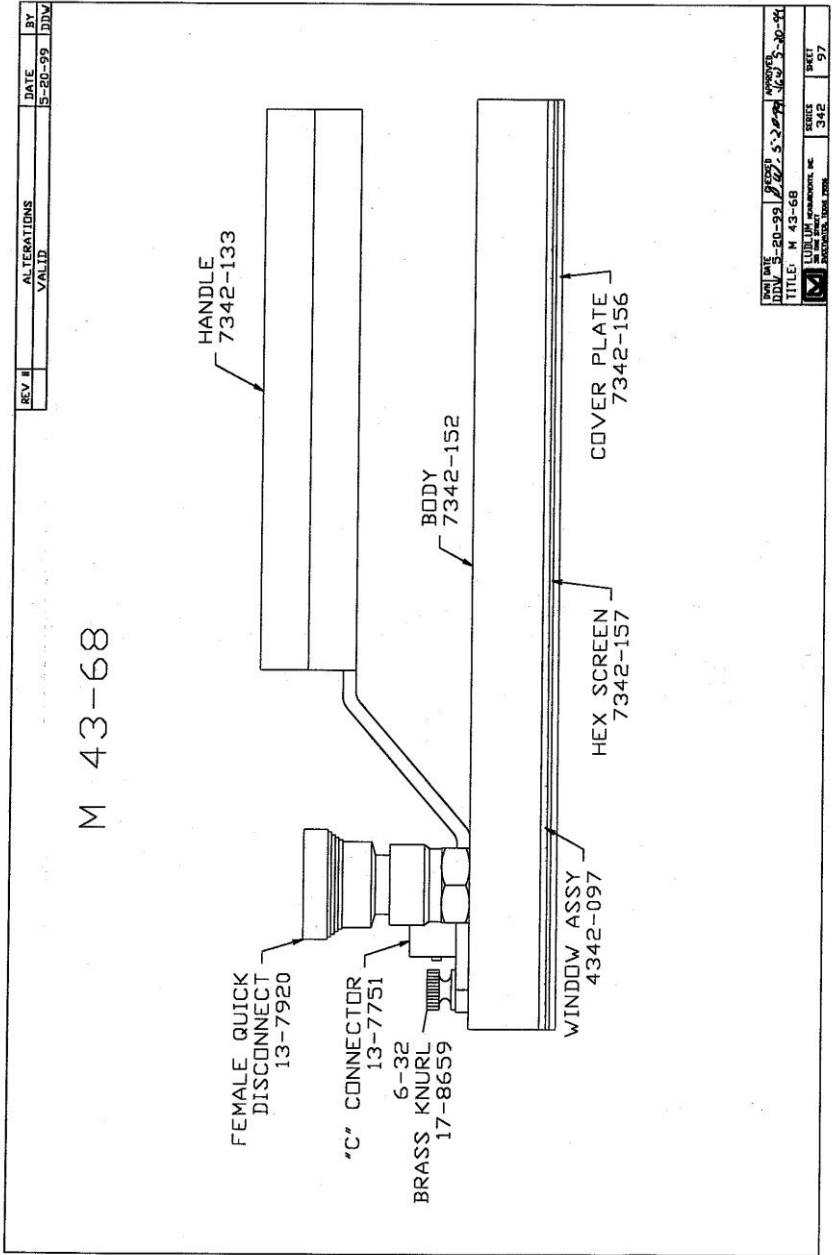

Model 43-68, 43-68/1, 43-68/2 Gas Proportional Detector

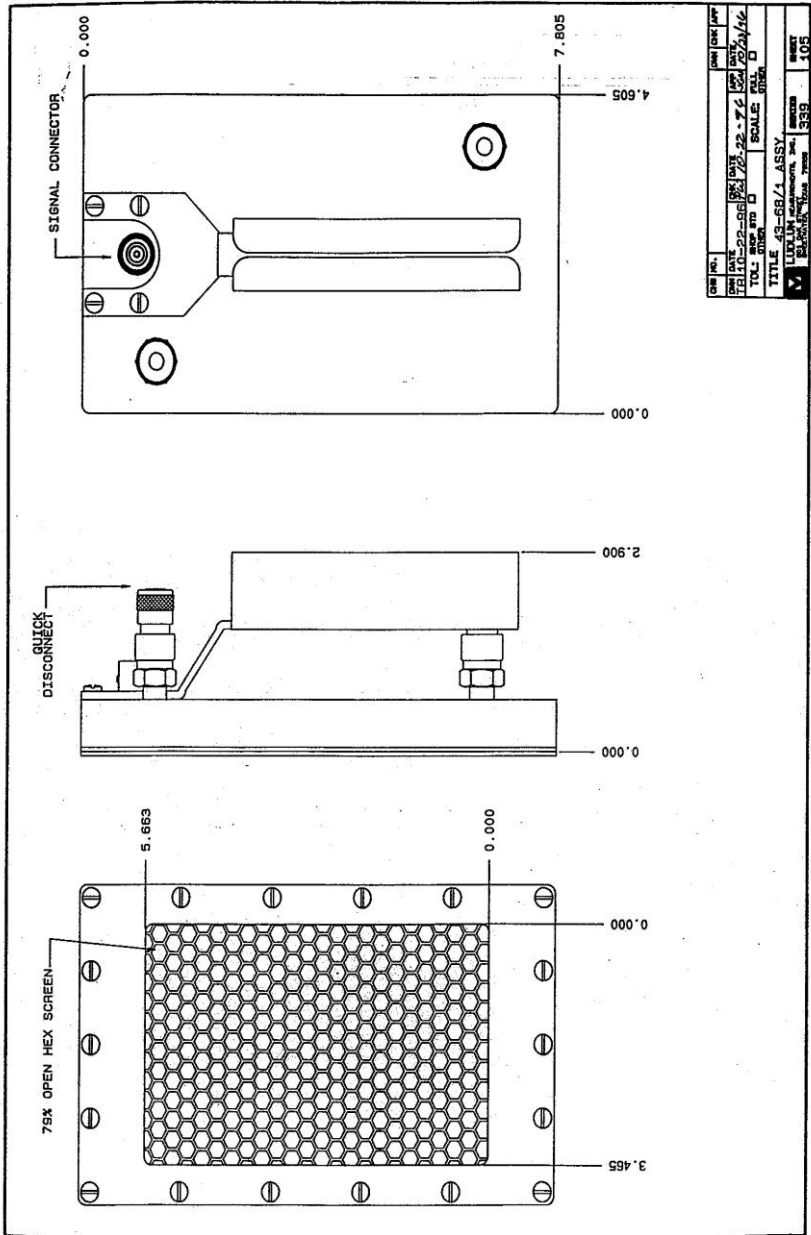

Model 43-68, 43-68/1, 43-68/2 Gas Proportional Detector

